

DURALINER HYBRID DUMPSTER

BUILT FOR DURABILITY, DESIGNED FOR VERSATILITY



LARGE-SCALE, HEAVY-DUTY MANUFACTURED DUMPSTERS



FEATURES

HYBRID DUMPSTER

This dumpster is built to withstand tough industrial environments, offering a durable and reliable solution for material handling needs. Its sturdy design ensures long-lasting performance, while its ease of mobility and low-maintenance materials make it a practical choice for maximizing efficiency in a wide range of applications.



- Currently Available as a 2yd Dumpster- 3yd and 4yd are coming soon
- Replaceable HDPE Single Wall Plastic Tub
- 14 Gauge Steel Frame with 10 Gauge 8"H x 24"L Pockets
- Vacuum Formed HDPE Plastic Lids
- 1/2" Diameter Zinc plated Steel Lid Rods with a Nylock Nut
- 6" Diameter Polyolefin QR Casters Fully Assembled with Greaseable Roller Bearings (2 Swivel & 2-Rigid)
- Industrial Enamel Primer & Paint



DURABLE

The combination of a 14-gauge steel frame and HDPE plastic construction ensures long-lasting performance in demanding environments.



MANEUVERABLE

6" Diameter Polyolefin QR casters with greaseable roller bearings allow for smooth and reliable movement.



RELIABLE

The steel frame with reinforced pockets adds strength and stability, making these dumpsters reliable under heavy-duty conditions.



CUSTOMIZABLE

Industrial enamel primer and paint available in multiple colors helps ensure brand standards and allows for specific customization.

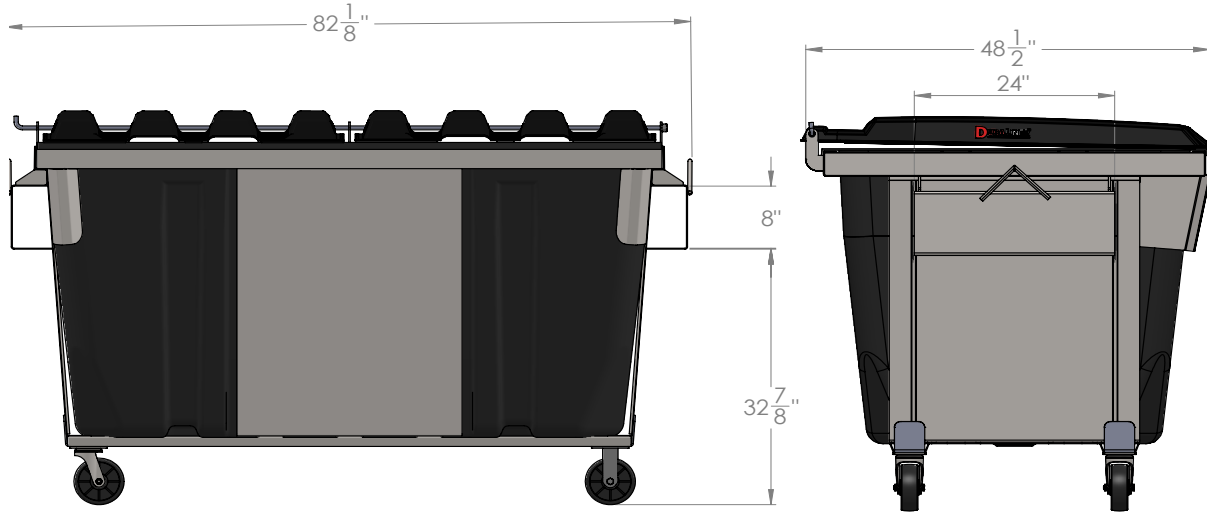

HYBRID DUMPSTER

MORE INFORMATION



Looking for a reliable and efficient way to handle waste management? Find your solution here. Follow the link on the left to learn more about DuraLiner Hybrid Dumpsters.

<https://www.penda.com/duralinerwastemanagement/>



Kruger Family Industries (KFI), the parent company of DuraLiner, warrants to the original purchaser only that products sold by KFI under the name DuraLiner are free from defects in material and workmanship, and against excessive wear under normal use for one (1) year from the date of purchase. KFI's obligation under this warranty is limited to the repair or replacement of covered products and only when the product has been returned, freight prepaid 2344 West Wisconsin Street Portage WI, 53901. KFI retains sole discretion in determining defective merchandise. There are no warranties which extend beyond the description on the face hereof.

